

Installation Information

In-Wall Thermostatic Control Valve

Description:

- ❖ Complies with ASME A112.18.1
- ❖ Safeguard: Valve shuts down automatically for hot or cold water failure
- ❖ User Friendly: Enjoy shower without repeated temperature adjustment
- ❖ Durable brass construction
- ❖ Pre-set water temperature: 104 - 108°F
- ❖ Minimum working pressure (Dynamic): 14.5 PSI
- ❖ Temperature Control Valve Only. A volume control valve is required for each additional function
 - ie: Showerhead, hand held shower or body spray, etc.

Attention:

Warranted only if installed by a qualified licensed plumber. Before installing the valve, be sure to flush the supply pipes thoroughly to remove any remaining debris. Failure to carry out this procedure could cause problems or damage to the operation of the valve and will void the manufacturer's warranty.

Connecting Water Supply

1. Thoroughly flush supply lines to remove any debris.
2. Shut off water supply to valve.
3. Hot and Cold water supplies **MUST** be connected to designated sides for proper operation of valve.
4. If solder/brazing the fitting connections, pre-assemble hot & cold adapter fittings to copper piping. Using Teflon tape or equivalent to attach adapter to appropriate inlet port. **IMPORTANT: All excessive heat shall be a minimum of 4" from valve.**
5. Connect outlet pipe to stop valve/volume control (not included), and from stop valve pipe to various end devices.
6. Turn on water supply to valve and check for leaks.

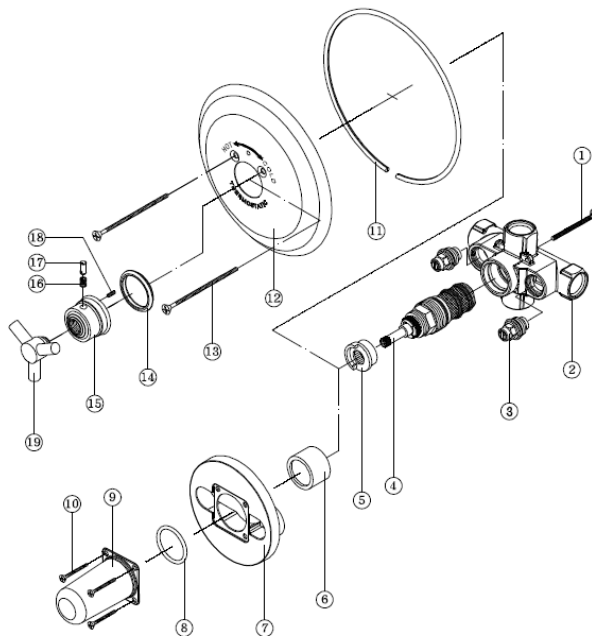

| | | | |
|----|--------------------------|----|----------------------------|
| 1 | Valve Positioning Screw | 11 | Outer Gasket |
| 2 | Thermostatic Body | 12 | Cover Face Plate |
| 3 | Check Valve | 13 | Face Plate Screws |
| 4 | Thermostatic Cartridge | 14 | Inner Gasket |
| 5 | Temperature Setting Seat | 15 | Temperature Handle Seat |
| 6 | Sleeve | 16 | Spring |
| 7 | Mud Guard Seat | 17 | Temperature Setting Button |
| 8 | O-ring | 18 | Temperature Setting Screw |
| 9 | Mud Guard Cover | 19 | Temperature Handle |
| 10 | Mud Guard Screws | | |

- A Fit the valve on the wall without removing the plastic cover on the control spindle. Turning the control spindle will change the temperature setting which is pre-calibrated at the factory.

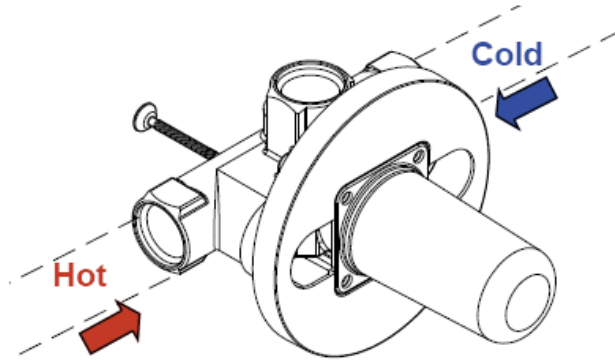

- B Connect the outlet pipe(s). Install tile stops/volume controls between the thermostatic valve and each device to be operated. See diagram for sample installations. Ensure bottom outlet is plugged if not being used.

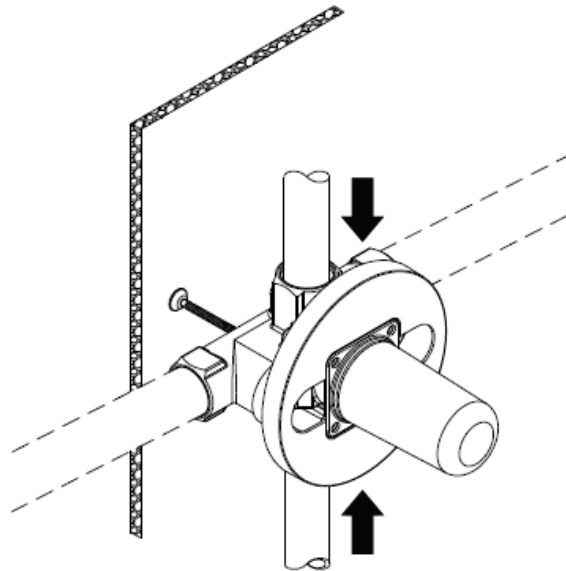

- C Measure the distance between the inner of front and back wall then adjust the (1) valve positioning screw to touch on the inner of back wall. This device and procedure is important which can avoid the displacement of the valve toward the back wall.

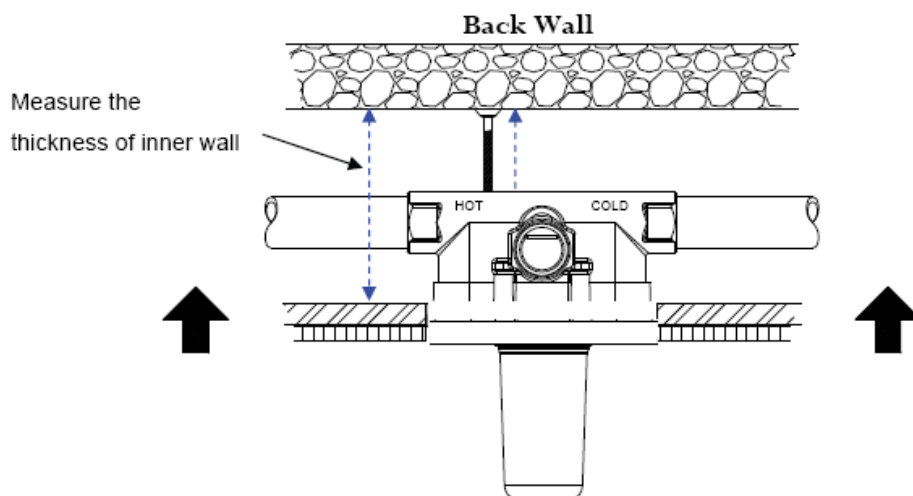

D After all wall construction completion, loosen (10) mud guard screws then take off the (9) mud guard cover.

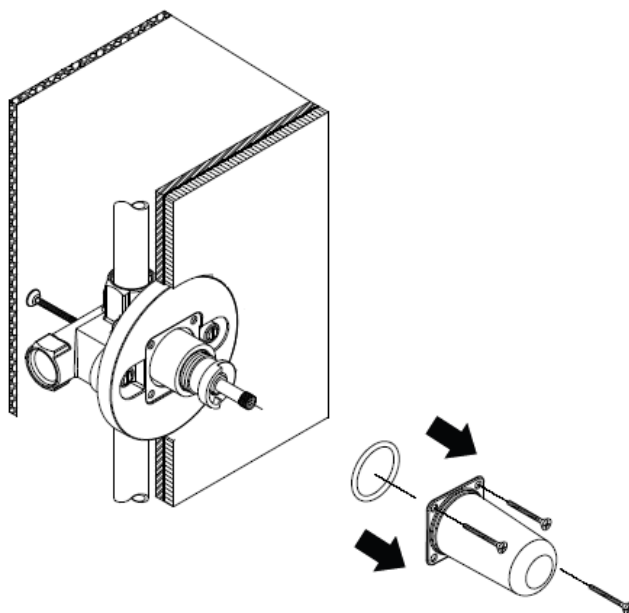

E Place the (12) faceplate over the retainer then tighten the (13) face plate screws to fix the face plate.

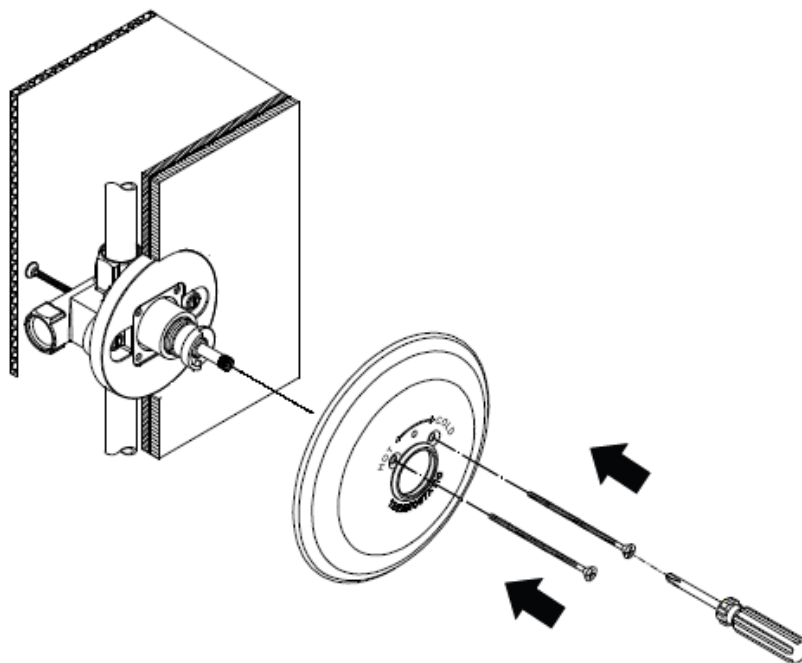

F Ensure that (17) temperature setting button is at 12 o'clock position, then straight place the handle kit on the (15) temperature setting seat. Make sure the handle can't be turned left which is the correct installation position.

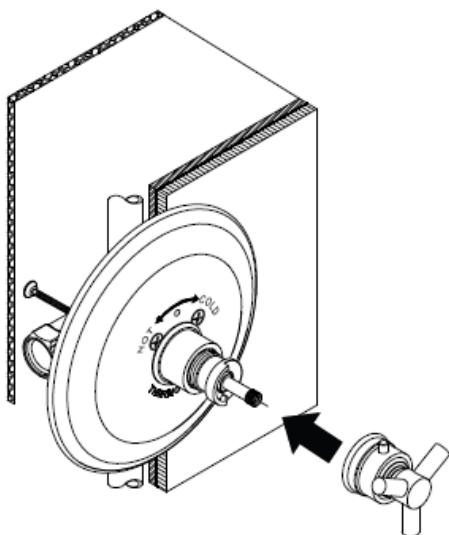

G Tighten the handle hexagon screws (pre-screwed in the handle) to fix the handle and handle seat.

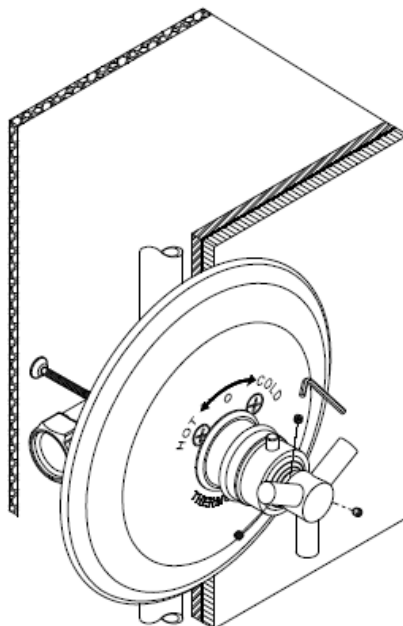

Maintenance

A soft cloth with clean water also be used.
No additional cleaning products are required.

Operation of Temperature Controller

For safety reasons, the water temperature is limited by a stop.

To obtain a higher than 40- 42 °C (104-108 °F), you need to press the SAFETY STOP on the temperature controller and continue to rotate the controller to left.

CAUTION !

Temperature over than 42 °C (108°F).

